

# GLOBAL ROTAX MAX Challenge Technical Regulation 2023

Bulletin no. : 02

Valid from : 2023 March 01

Addendum/changes (highlighted in yellow) to Global RMC Technical Regulation 2023, Edition 2022 09 27 Version 1

## 5.6 INLET SYSTEM

### 5.6.1 Reed valve assy.

The reed valve assy. is equipped with 2 petal stops and 2 reeds, each having 3 petals.

	Thickness	Tolerance
Reed Valve	0,6 mm	+0,10 mm -0,10 mm

Flattening of the curved reed valve stopper plates is forbidden.

The minimum gap between the 2 stopper plates must be greater than 17.00mm.

The measurement must be taken using a digital calliper from the inside surface of the stopper plates in line with the middle of each reed petal, as indicated by the red lines in the picture.



**For 125 Micro MAX and 125 Mini MAX only.**

It is mandatory to add 2 x additional “distance plates” to the reed block assy.

The “distance plates” must be secured tightly between the reed petals and the curved stopper plate on both sides of the reed assy and in the order as show in the diagram. The ROTAX markings must be facing the stopper plate as shown in the diagram.

It is allowed to install upto 2 gaskets between the reed block assy and the cylinder.

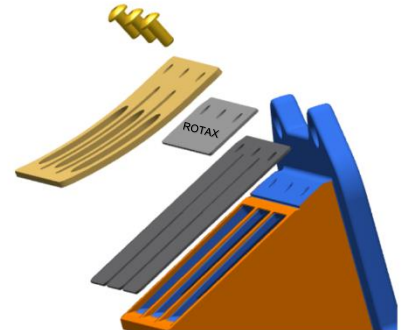

**For Information only / non-tech item:**

The assembly should utilize only oval head screws M3x6 (ROTAX Part number 240351).

The use of tap tight fixings is not recommended for this application.

For identification purposes that the distance plates are installed, a M6 washer should be placed under the bolt which is secured with the seal in position 1, as indicated in the picture.

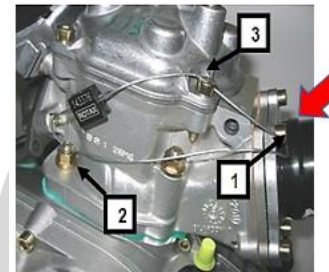

The 2 x distance plates must be engraved ROTAX (as per the drawing below) with the part number 910224380 visible on the plate.

The plate must be flat with no curvature, when held against a straight edge no crack of light should be visible between the two surfaces, and meet the below specification.

	Measurement	Tolerance
<b>A</b>	22,00 mm	+0,2 mm -0,2 mm
<b>B</b>	10,00 mm	+0,3 mm -0,3 mm
<b>C</b>	16,00 mm	+0,3 mm -0,3 mm
<b>D</b>	66,00 mm	+0,7 mm -0,7 mm
<b>Distance plate thickness</b>	0,70 mm	+0,08 mm -0,08 mm
<b>Location holes</b>	3,3 mm	+0,2 mm -0,2 mm

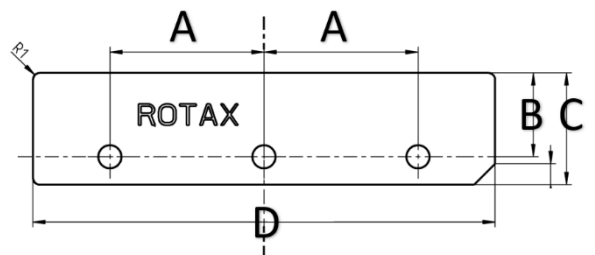

### 6.7.3 Pick up

The marking of the pick-up must show the following numbers in the first line 029600-0710.

A steel ball (diameter 3-5 mm) placed on circular surface of the sensor must stay in the center of the circular surface.



#### For 125 Junior MAX, 125 Senior MAX and 125 MAX DD2

Mounting the pick-up to the crankcase with a gasket additional to the original rubber sealing ring of the pick-up, is a legal specification.

Additional gasket, Rotax 431500, gasket thickness = 0,8 mm  
Maximum two gaskets (Rotax 431500) are allowed to be fitted.

Fitting Position of the additional gasket(s):

Crankcase – rubber sealing ring – additional gasket(s) – pick-up.

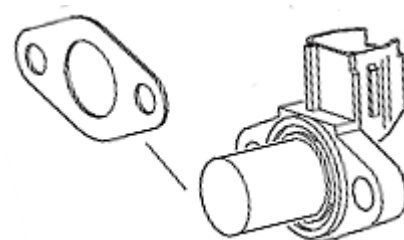

#### Note

It is not necessary to install any additional gasket/s with the exception of the rubber sealing ring on crankcases with the machined sealing surface for the pick-up sensor.

#### For 125 Micro MAX and 125 Mini MAX

The only engines allowed to be used without 1 x additional gaskets in the pick-up area assembly are engines with the following combination of crankcases casting codes :

6211885 (ignition sensor side) and 6211893 (clutch side)

These crank cases are supplied with original machined surfaces for the pick-up sensor.

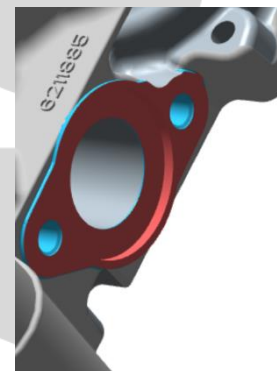

All other crankcases must have with the pick-up assembled with 1 x Additional gaskets

(Rotax 431500), gasket thickness = 0,8 mm

Fitting Position of the additional 1 x gaskets:

Crankcase – rubber sealing ring – 1 x additional gaskets – pick-up.

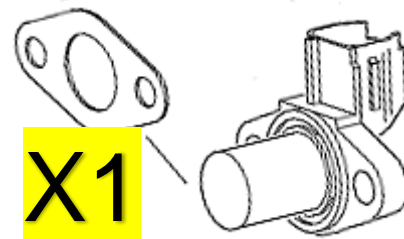

**Note: For all RMC International, Zone or National events in 2024 the only crankcases allowed for racing in the 125 Micro MAX and 125 Mini MAX categories will be the original machined pick-up flange type with casting codes 6211885 (ignition sensor side) and 6211893 (clutch side)**

### 6.17 125 MICRO MAX

A specific Exhaust system has to be used for the 125 Micro MAX engine.

ROTAX Part number 273136

The Exhaust external body is a common component to Mini MAX, but with alternative internal components (*Inserts*).

The silencer must be mounted in a Position where the direction of the 90° elbow outlet (*direction of the hot exhaust gasses*) does not harm any component of the chassis.

The exhaust must be mounted and secured in such a way to ensure a full sealing around the exhaust socket and the gasket ring.

The measurements in the diagram to the right are as follows:

- (a) 580 mm +/- 5mm
- (b) 299 mm +/- 5mm
- (c) 42 mm +/- 3mm

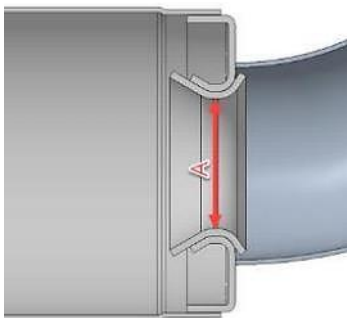
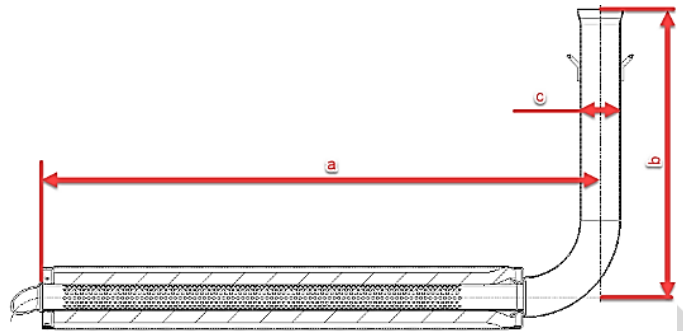

A steel ball with a 28.0mm diameter or solid flat plate measuring 28.0mm and 1.5mm thick **must not** pass through Section "A" and a steel ball with a 26.0mm diameter must be able pass through Section "A" in the below diagram from the inlet and through the 90-degree elbow completely. All exhaust gases must pass through Section "A".

(Internal exhaust components must first be removed)

The inner measurement of the exhaust system silencer end (a) in the diagram must be a maximum of 63.0 mm.

#### Note

This is not a measurement of the perforated tube

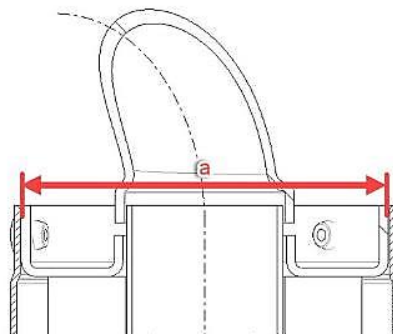

The Exhaust must be installed firmly to the chassis using a rigid mount/s.

The Exhaust must be mounted to the rigid mount/s using 2 ROTAX silent blocks.

(Part 660920 and or 260657 allowed).

The deflection of the 2 silent blocks is the only Exhaust movement allowed.

The Exhaust must be mounted in a neutral Position with no stress on the 2 silent blocks.

**125 Micro MAX Perforated tube**

ROTAX part number: 273212

The measurements in the diagram below are as follows:

- (a) at least 498 mm
- (b) minimum outside diameter of 61 mm
- (c) maximum outside diameter of 26 mm
- (d) minimum length 63 mm

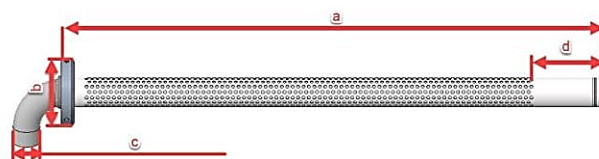

The measurement in the diagram to the right is as follows:

- (a) minimum outside diameter of 26.0mm



The only legal Isolation matting for 125 Micro MAX is:

ROTAX part number 297982	Measurement	Tolerance
<b>New size minimum</b>	480 x 270 mm	+10 mm
		-10 mm
<b>New weight</b>	207 Gram	+31 Gram
		-31 Gram
<b>Used weight (old)</b>	245 Gram	+105 Gram
		-105 Gram

**Note**

The only exhaust system allowed for racing in the 125 Micro and 125 Mini MAX category's is the MY2020 version.

The exhaust has 3 clear visual differences to identify the MY2020 version.

1. Exhaust hooks
2. Connecting socket / ball joint connect at manifold
3. Wall thickness of the exhaust system is 1.0mm (older exhaust system which is not allowed for racing has a wall thickness of 1.5mm)

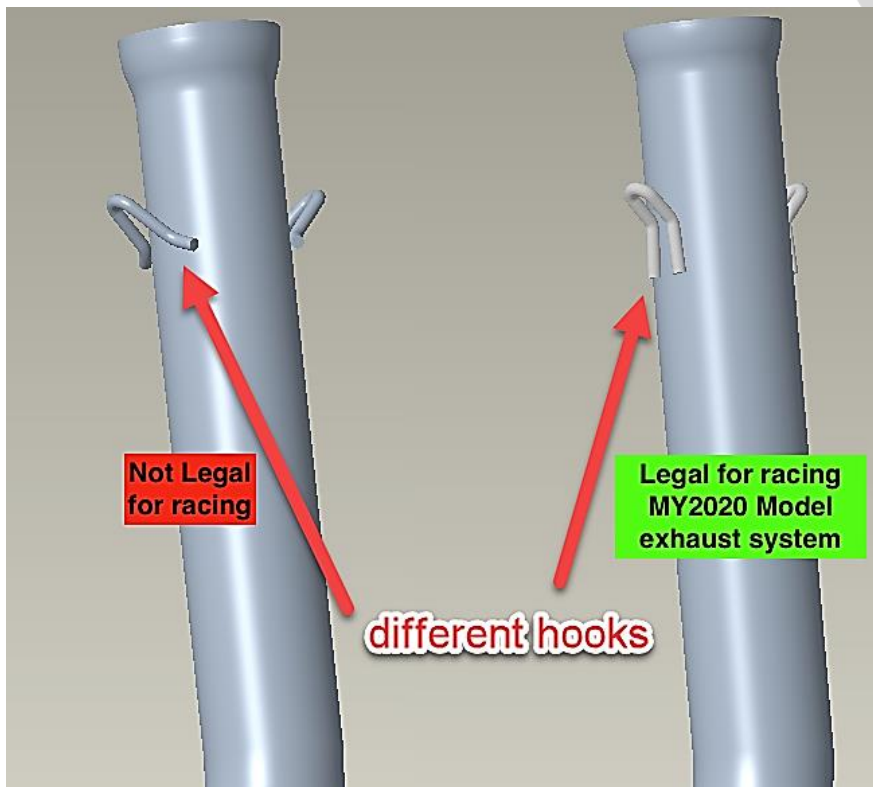



### 6.18 125 MINI MAX

A specific Exhaust system has to be used for the 125 Mini MAX engine.

ROTAX Part number 273137

The Exhaust external body is a common component to Micro MAX but with alternative internal components.

The silencer must be mounted in a Position where the direction of the 90° elbow outlet (**direction of the hot exhaust gasses**) does not harm any component of the chassis.

The exhaust must be mounted and secured in such a way to ensure a full sealing around the exhaust socket and the gasket ring.

The measurements in the diagram below are as follows:

- (a) 580 mm +/- 5mm
- (b) 299 mm +/- 5mm
- (c) 42 mm +/- 3mm

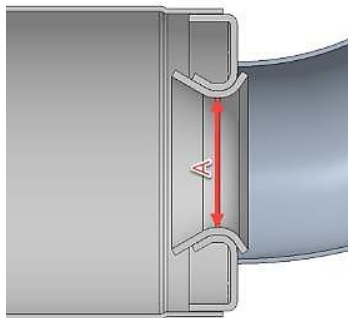
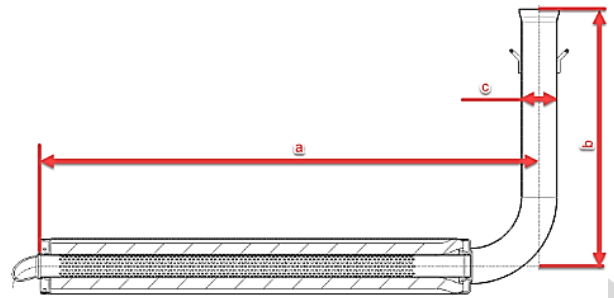

A steel ball with 28.0mm diameter or solid flat plate measuring 28.0mm and 1.5mm thick **must not** pass through Section "A" and a steel ball with 26.0mm diameter must be able pass through Section "A" in the below diagram from the inlet and through the 90-degree elbow completely. All exhaust gases must pass through Section "A".

(Internal exhaust components must first be removed)

The inner measurement of the exhaust system silencer end (a) in the below diagram must be a maximum of 63.0 mm.

**Note**

This is not a measurement of the perforated tube

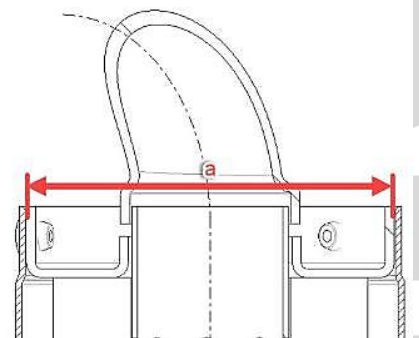

The Exhaust must be installed firmly to the chassis using a rigid mount/s.

The Exhaust must be mounted to the rigid mount/s using 2 ROTAX silent blocks. (Part 660920 and or 260657 allowed).

The deflection of the 2 silent blocks is the only Exhaust movement allowed.

The Exhaust must be mounted in a neutral Position with no stress on the 2 silent blocks.

**125 Mini MAX Perforated tube**

ROTAX Part number 273211

The measurements in the diagram below are as follows:

- (a) at least 482mm
- (b) minimum outside diameter of 61 mm
- (c) maximum outside diameter of 26 mm
- (d) at least 63 mm

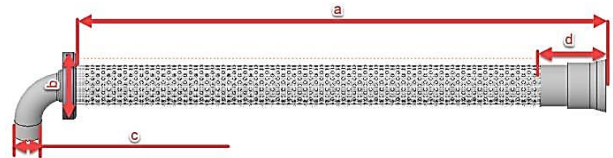

**Note**

Mini MAX perforated tube has a stamped ID marker "X" visible externally.

The only legal Isolation matting for 125 Mini MAX is:

ROTAX part number 297985	Measurement	Tolerance
<b>New size minimum</b>	490 x 180 mm	+10 mm
		-10 mm
<b>New weight</b>	141 Gram	+22 Gram
		-22 Gram
<b>Used weight (old)</b>	230 Gram	+120 Gram
		-120 Gram

